

IP5 Top Terminal Battery Cabinet

Features:

-  UL Listed 5th Edition.
- IBC 2018 Seismic Certified.
- Designed for 40 standard 12 volt top terminal batteries in 480VDC nominal configuration.
- One of the tightest footprints available. A space saving footprint saves valuable equipment room floor space.
- Cabinet mechanical features:
 - Welded heavy gauge steel.
 - Acid resistant powder coat epoxy paint.
 - Doors and panels are removable, easing installation and maintenance.
 - Front and back of cabinet is accessible to standard material handling equipment.
 - Can be installed in single or multiple cabinet lineup.
 - Locking right door has pocket to hold manuals and maintenance records.
 - Designed to accommodate monitor harness installation.
 - Dedicated area for electrical output connections and cable routing.
 - Improved ventilation through rear, top, and side panels.
 - Removable side panels are designed as universal for installation on either side of frame.
 - Batteries are accessible from all sides of the cabinet.
- System electrical features:
 - DC rated breakers in each cabinet with UVR or Shunt Trip and Aux Contacts.
 - Breaker installed horizontally to lessen the chance of opening during a seismic event.
 - Accommodates multiple manufacturers' breaker designs.
 - Removable breaker mount for other optional output connections.
- Optional items include:
 - Floorstands
 - Seismic Anchor Brackets
 - Spill Containment Pan System
 - Installation of battery monitors or harnesses
 - Junction cabinets for one connection point to the UPS
 - Forced air fan assemblies

Designed for 480VDC nominal battery systems

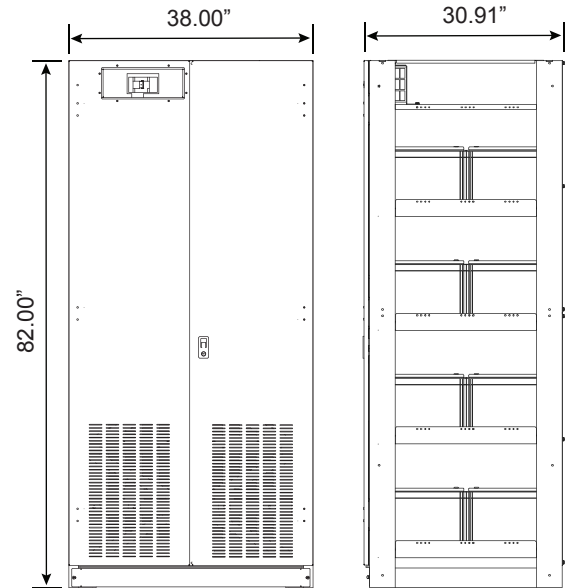

Front View

Right Side View

Dimensions shown for the frame only

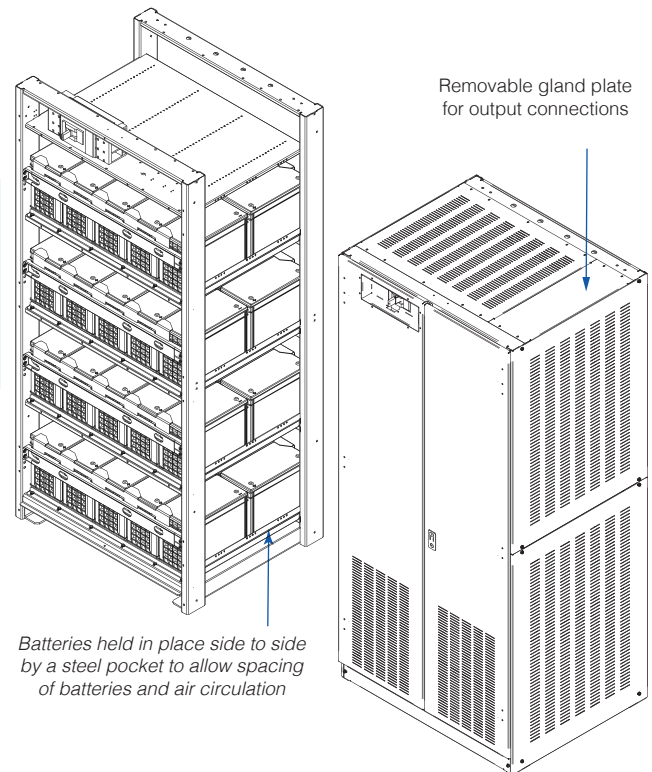

Removable gland plate for output connections

Batteries held in place side to side by a steel pocket to allow spacing of batteries and air circulation

Top view and bottom view shown with panels.
Each panel adds 0.09" to the width.

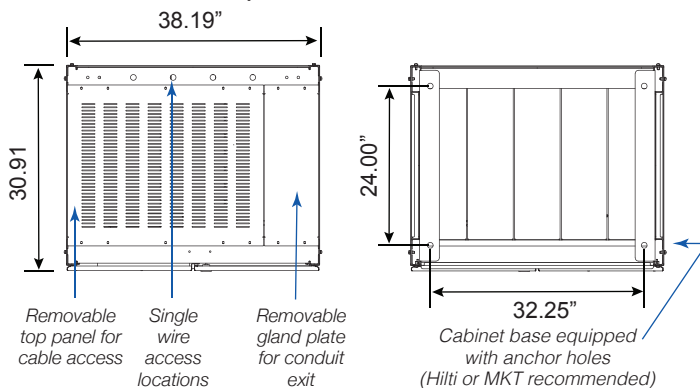

For applications assistance, please contact sales@IntraPack.com or call 214-348-7105

Effective Date: 07/16/19