

# IP1 Battery Cabinet

Designed for 120VDC & 216VDC Link UPS Systems

Effective Date: 03/29/11

Bulletin Number: 119230-1

## Features:

-  UL Listed with factory assembly.
- IBC 2006 Seismic Certified.
- One of the tightest footprints available. A space saving footprint saves valuable equipment room floor space.
- Designed to accommodate all VRLA UPS battery makes and models.
- Cabinet mechanical features:
  - Welded heavy gauge steel welded construction.
  - Acid resistant powder coat epoxy paint.
  - Doors and panels remove easing installation and maintenance.
  - Front and back of cabinet accessible to standard material handling equipment.
  - Can be installed in single or multiple cabinet lineup as adjacent to each other or in a remote configuration.
  - Side panels designed as universal for installation on either side.
  - Dedicated area for electrical output connections and cable routing.
  - Designed for monitor harness installation.
  - Locking right door has pocket for manuals and maintenance records.
  - Knockouts are spaced apart to allow up to 4" conduit.
- System electrical features:
  - DC rated breakers in each cabinet with UVR or Shunt Trip and 2A/2B Aux. Contacts.
  - Breaker installed horizontally to lessen the chance of opening during a seismic event.
  - Batteries accessible from all sides of the cabinet.
- Optional items include:
  - Floorstands
  - Seismic Anchor Brackets
  - Spill Containment Pans
  - Installation of battery monitors or harnesses
  - Main battery system breaker rated up to 2500 amps in separate line up and match frame.

For applications assistance or system specific drawings of a lineup configuration, please contact the IntraPack Staff.

Locking right door has pocket for manuals and maintenance records

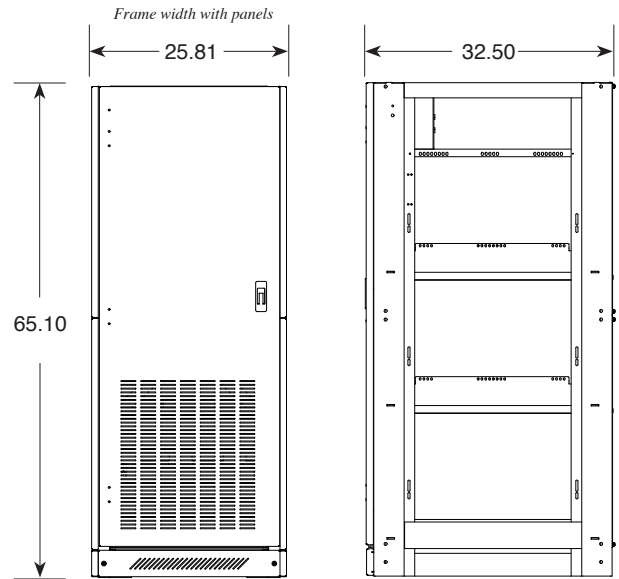

Front view and side view  
all measurements shown in inches

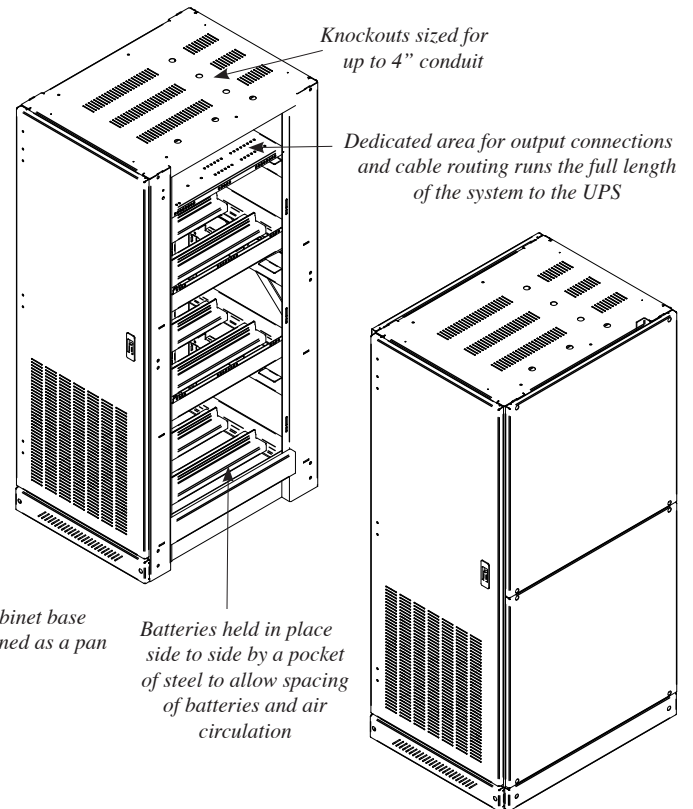

Isometric views shown with and without side panels

Top view and bottom view shown with panels. Each panel adds .87" to the width

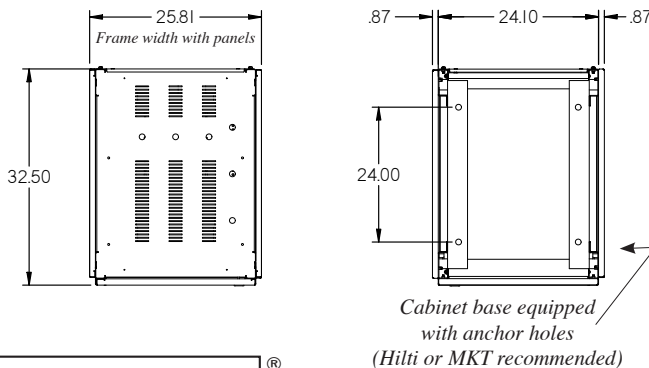

Not a purchase, an investment.

10817 Sanden Drive • Dallas, Texas 75238-1338  
Tel: 214-348-7105 • Fax: 214-348-7115 • Email: sales@intrapack.com